

Model No. UC3551A ELECTRIC CHAIN SAW 350MM

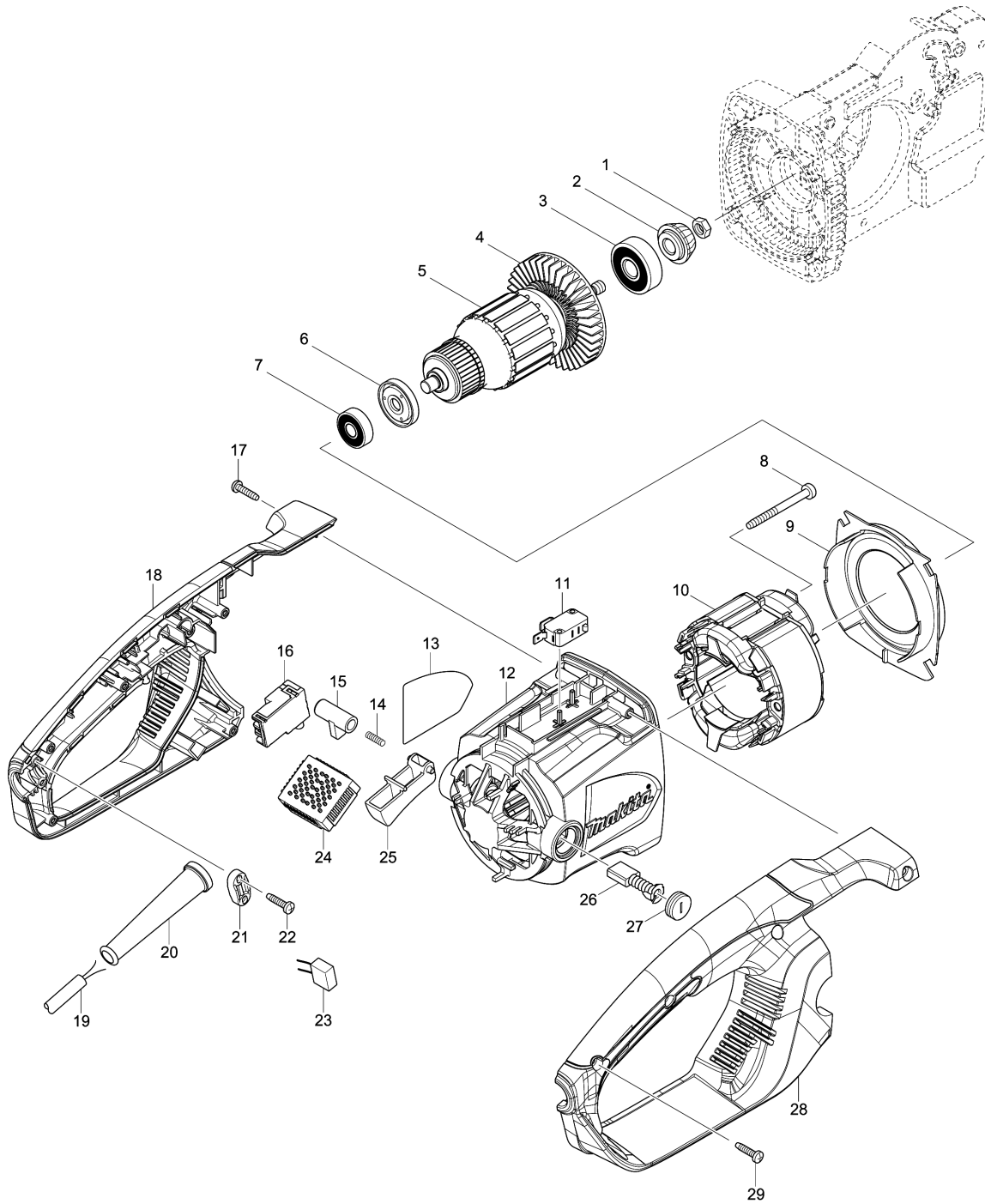

Model No. UC3551A ELECTRIC CHAIN SAW 350MM

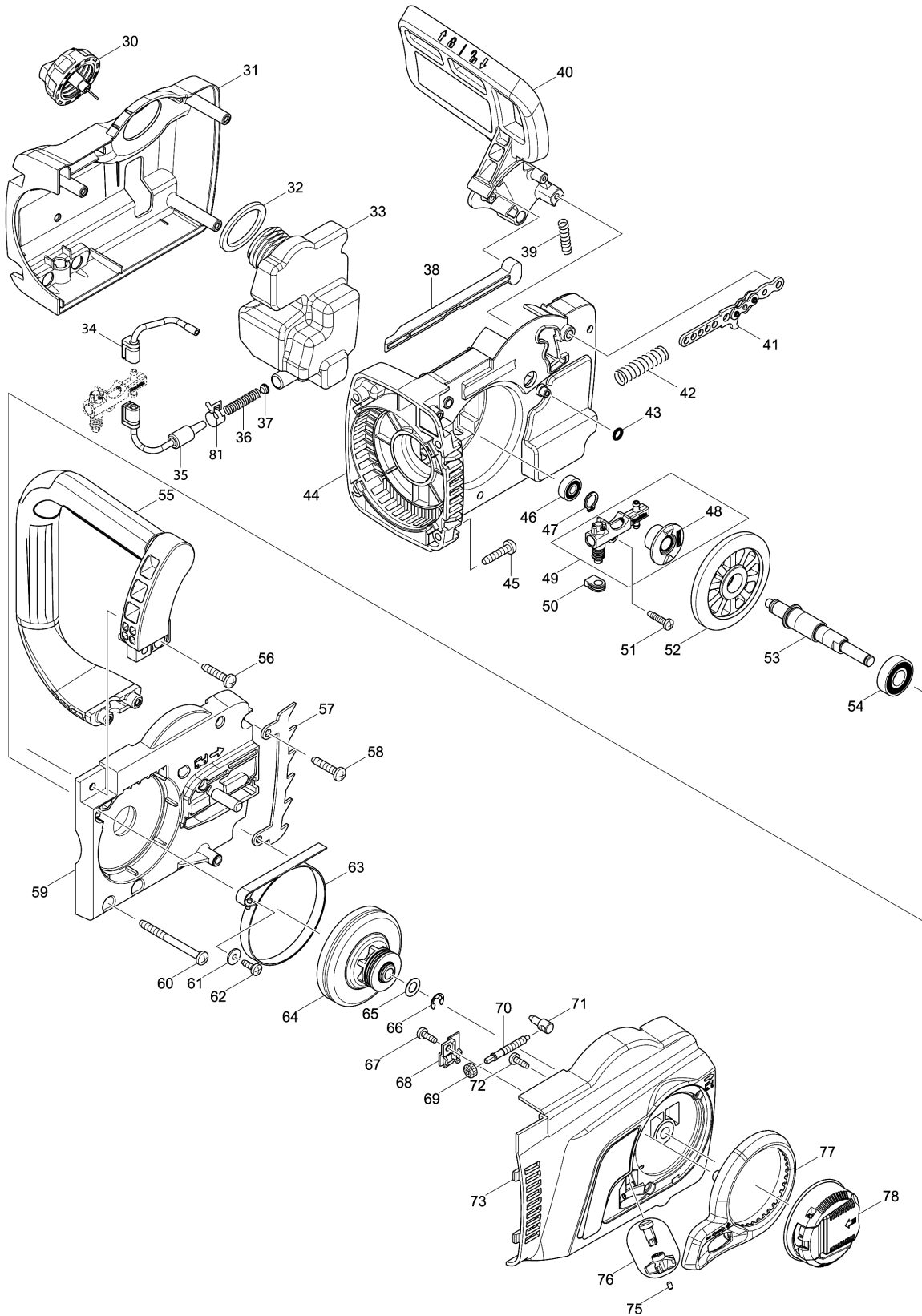

Model No. UC3551A ELECTRIC CHAIN SAW 350MM

Position	Référence pièce	Description	Echange	QTE	New/Old	Option 1	Option 2	COMMENTAIRE
001	931403-6	ECROU M8		1		65	P1	
002	227626-5	PIGNON 12		1			P10	
003	211111-8	ROULEMENT A BILLES 6301		1		1	P20	
004	240003-4	VENTILATEUR 80		1		2	P9	
005	517904-4	INDUIT		1			P29	
D10		INC. 3,4,6,7						
006	681666-1	RONDELLE		1		0	P1	
007	210084-2	ROULEMENT A BILLES 629ZZ		1			P1	
008	266095-5	VIS 5X55		2		0	P3	
009	419410-4	PLAQUE DE VENTILATION		1		0	P1	
010	636394-3	INDUCTEUR 240V		1			P25	
011	650577-1	INTERRUPTEUR ES-33/38/42A		1		0	P3	
012	142348-5	CARTER MOTEUR COMPLET		1			P17	
C10	643653-8	PORTE-CHARBON 6.5-13.5		2	*		P7	
C11	643536-2	BRUSH HOLDER 6.5X13.5	<	2				
013	815F99-6	UC3551A NAME PLATE		1				
014	233173-6	RESSORT DE COMPRESSION 4		1		0	P1	
015	416178-3	BOUTON SECURITE		1		0	P1	
016	650717-1	INTERRUPTEUR TGC30B		1			P1	
017	265995-6	VIS 4X18		1		0	P1	
018	187901-0	JEU DE POIGNEES		1			P16	
C10	802G51-9	CAUTION LABEL		1				
D10		INC. 28						
019	665883-1	CABLE D'ALIMENTATION 1.0-2-5.0		1			P23	
020	682540-6	MANCHON CABLE 9,3-90		1			P4	
021	687124-5	BARETTE DE FIXATION		1		0	P1	
022	265995-6	VIS 4X18		2		0	P1	
023	645105-5	CONDENSATEUR ANTIPARASITES		1			P8	
024	631719-6	CONTROLEUR UC3030A/3530A/4030A		1		3	P24	
025	419411-2	INTERRUPTEUR UC3030A,3530A		1		0	P1	
026	181044-0	JEU DE CHARBON CB-153 <9100		1		4	P13	
027	643650-4	BOUCHON PORTE-CHARBON CB5		2	*	1	P4	
027-1	643650-4	BOUCHON PORTE-CHARBON CB5	O	2		1	P4	
028	187901-0	JEU DE POIGNEES		1			P16	
C10	802G51-9	CAUTION LABEL		1				
D10		INC. 18						
029	265995-6	VIS 4X18		6		0	P1	
030	142282-9	BOUCHON RESERVOIR CPL		1			P5	
031	454822-4	COUVERCLE CARTER		1			P1	
032	421959-2	JOINT		1		0	P1	
033	454826-6	RESERVOIR D'HUILE		1			P67	
034	424611-1	CONNECTEUR B		1			P1	
035	424610-3	CONNECTEUR A		1			P1	
036	231975-4	RESSORT		1		0	P1	

Please order the parts with part number.

Print Date 3/7/2019

Model No. UC3551A ELECTRIC CHAIN SAW 350MM

Position	Référence pièce	Description	Echange	QTE	New/Old	Option 1	Option 2	COMMENTAIRE
037	416274-7	BOUCHON		1		0	P1	
038	454825-8	BIELLE		1			P1	
039	233174-4	RESSORT		1		0	P1	
040	142341-9	PROTECTION POIGNEE CPL		1			P8	
C10	802K54-7	INDICATION LABEL		1				
041	158044-5	SUPPORT DU RESSORT DE FREIN		1		1	P5	
042	234005-0	RESSORT		1		0	P1	
043	213017-6	O RING 6		1		0	P1	
044	454821-6	CARTER ENGRENAGE MT903		1			P12	
045	266041-8	VIS AUTOFORMEUSE EPAULEE 5X25		4		65	P2	
046	210028-2	ROULEMENT A BILLES 606ZZ		1	*	65	P2	
046-1	210206-4	BALL BEARING 606ZZ	O	1				
047	961006-2	CIRCLIP MOD S EXT 10		1		65	P1	
048	221427-3	PIGNON		1			P4	
049	196419-0	POMPE A HUILE		1	*		P99	
D10		INC. 48			*			
049-1	142156-4	POMPE A HUILE CPL	<	1			P64	
050	424612-9	BAGUE DE COMPRESSION		1			P1	
051	265995-6	VIS 4X18		1		0	P1	
052	227627-3	PIGNON 37 HR3000C		1			P12	
053	326373-6	AXE		1			P7	
054	210107-6	BALL BEARING 6001ZZ		1	*	65	P2	
054-1	210205-6	BALL BEARING 6001ZZ	O	1				
055	454823-2	POIGNEE TUBULAIRE		1			P17	
056	266041-8	VIS AUTOFORMEUSE EPAULEE 5X25		2		65	P2	
057	345651-5	GRIFFE		1		0	P1	
058	266041-8	VIS AUTOFORMEUSE EPAULEE 5X25		2		65	P2	
059	319091-3	CARTER ROULEMENT		1			P17	
060	266044-2	VIS 5X60		2		1	P5	
061	267195-4	RONDELLE PLATE 4		1		0	P1	
062	266026-4	VIS AUTO-FOREUSE 4X12		1		0	P1	
063	168426-3	RESSORT DE FREIN		1		1	P5	
064	125331-7	TAMBOUR CPL		1	*	85	P16	
064-1	123886-6	TAMBOUR CPL	O	1				
065	253215-0	RONDELLE PLATE 8		1		0	P1	
066	259033-4	CIRCLIP		1		0	P1	
067	266427-6	VIS 4X12		1		0	P1	
068	454818-5	COUVERCLE		1			P1	
069	227496-2	PIGNON CONIQUE DROIT 14		1		2	P7	
070	326372-8	VIS DE REGLAGE		1			P1	
071	326310-0	ECROU DE TENSION		1			P1	
072	266427-6	VIS 4X12		3		0	P1	
073	142342-7	CARTER PIGNON		1	*		P9	
073-1	183B54-5	CARTER PIGNON CPL	<	1			P21	
C10	142342-7	CARTER PIGNON		1			P9	
D10		INC. 67-73,75-78						

Please order the parts with part number.

Print Date 3/7/2019

Model No. UC3551A ELECTRIC CHAIN SAW 350MM

Position	Référence pièce	Description	Echange	QTE	New/Old	Option 1	Option 2	COMMENTAIRE
075	263002-9	CHEVILLE CAOUTCHOUC 4		1		0	P1	
076	142665-3	ENGRENAGE CPL		1			P6	
077	454819-3	COUVERCLE		1			P1	
078	142235-8	ECROU CPL		1			P9	
081	324685-1	COLLIER		1		65	P2	
A01	158024-1	ATTACHE-CABLE D'ALIMENTATION		1		2	A9	
A02	165201-8	GUIDE 35cm 1,3 3/8		1		4	A20	
A03	419288-5	COUVERCLE PROTECTION CHAINE		1			A6	
A04A	196212-2	CHAINE 35CM - 1,3 - 3/8"LP - 52 MAILLONS		1			A19	
A04D	196212-2	CHAINE 35CM - 1,3 - 3/8"LP - 52 MAILLONS		2			A19	
A05D	195089-2	CHAIN EDGER SET		1				
A06D	195093-1	CHAIN OIL SET		1			P99	
A07D	823333-4	COFFRETMET 580x275x225UC3520AK		1		8	A32	
E01	805011-8	SOUND 103DB LABEL		1				

Please order the parts with part number.

Print Date 3/7/2019